

GREYSTONE ENERGY SYSTEMS INC

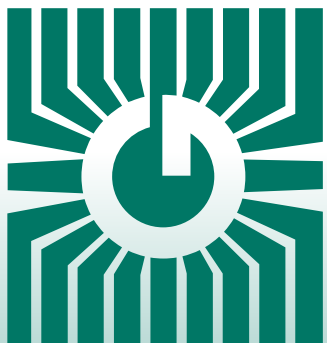

MINI-CURRENT SWITCH CS Series



Precision power control/sensing

FEATURES:

- Solid Core
- Go/No Go or Field Adjustable Models
- Up to 100 amps input current (CS-GnG-100)
- Up to 75 amps input current (CS-610-75)
- Small, Compact Design

*Peace of mind
through reliable
current monitoring*

GREYSTONE HAS AN **ISO 9001** REGISTERED QUALITY SYSTEM

DESCRIPTION:

The CS Series mini current switches monitor line current for electrical loads such as pumps, conveyors, lighting, heaters or fans and closes the output contacts when the trip point is exceeded. The CS-GnG-100 has a factory set trip point of 0.5 Amps to provide Go/No Go status operation. The CS-610-75 has a trip setpoint that is adjustable between 0.75 to 75 Amps by rotating the adjustment pot.

The sensor requires no external power as it is totally powered by induction from the AC line being monitored. The switch output is normally open and when the input current exceeds the trip setpoint the switch closes to provide an on/off digital signal to the controller

SPECIFICATION:

Current Setpoint	Fixed at 0.5 Amps (CS-GnG-100) 0.75 to 75 Amps (CS-610-75)
Maximum Input Current	100 Amps continuous (CS-GnG-100) 75 Amps continuous (CS-610-75)
Sensor Power	Self-powered
Output Type	Solid-state mosfet
Output Switch Action	Normally open
Output Switch Ratings	30 Vac/dc, 500 mA Max.
Indication	Status LED (CS-610-75 Only)
Von @ 24 Vdc at 500mA	< 50 mV
Frequency	50/60 Hz
Response Time	200 mS Typical
Insulation Class	600 Vac, insulated conductors
Operating Temperature	-15 to 60 °C (5 to 140 °F)
Operating Humidity	5 to 90% RH non-condensing
Terminal Block	14 to 22 AWG
Dimensions.....	48 x 49 x 21 mm 1.9 x 1.93 x 0.83 in)
Sensor Aperture.....	11.4 mm (0.45 in)
Enclosure Material.....	ABS/PC, UL94 V-0
Agency Approvals.....	cULus Listed

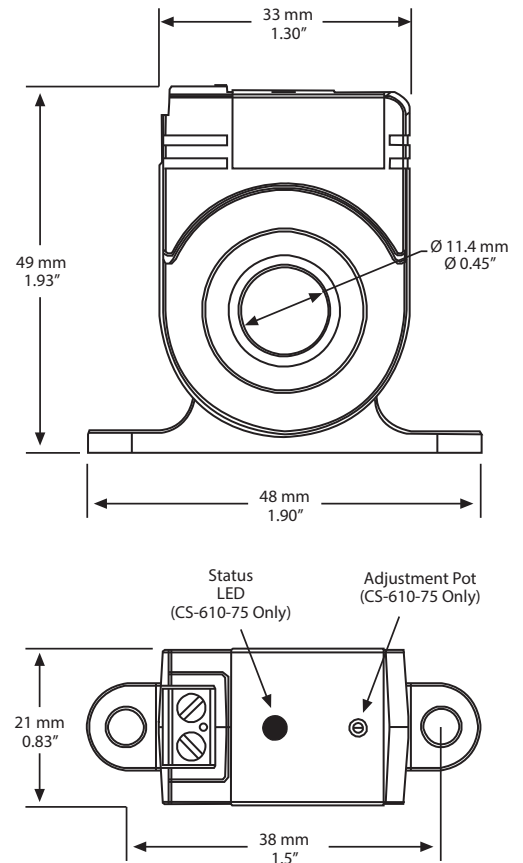

ORDER INFORMATION:

CS-GnG-100	Go/No Go
CS-610-75	Adjustable



GREYSTONE
ENERGY SYSTEMS INC

Greystone Energy Systems Inc.
150 English Drive, Moncton,
New Brunswick, Canada E1E 4G7
(506) 853-3057 Fax: (506) 853-6014
North America: 1-800-561-5611
e-mail: mail@greystoneenergy.com
www.greystoneenergy.com



Greystone Energy Systems Inc. is one of North America's largest ISO registered manufacturers of HVAC/R sensors and transmitters for Building Automation Management Systems.

We have conscientiously established a worldwide reputation as an industry leader by maintaining leading-edge design technology, prompt technical support, and a commitment to on-time deliveries. We take pride in our Quality Management System which is ISO 9001 certified, assuring our customers of consistent product reliability.

GREYSTONE HAS AN ISO 9001 REGISTERED QUALITY SYSTEM